



Propiedades especiales

- Carcasa con valona de aluminio anodizado
- Dos láminas deslizantes JUM-02 de iglidur® J están contenidas de modo estándar
- Tolerancia recomendada para el eje: h6 - h9

mm

DryLin® R

Teléfono +34 - 936 473 950

Fax +34 - 936 473 951

igus® S.L.

Internet www.igus.es

email info@igus.es

Especificación longitud de guía y superficie efectiva de cojinete FJUMT

Nº. de artículo	Tamaño diámetro nominal [mm]	Longitud de guía FJUMT-01/02-.. [mm]	Superficie de cojinete proyectada FJUMT-01/02-.. [mm²]
FJZMT-01/02-08	08*	45	256
FJUMT-01/02-10	10	52	250
FJUMT-01/02-12	12	57	324
FJUMT-01/02-16	16	70	464
FJUMT-01/02-20	20	80	580
FJUMT-01/02-25	25	112	975
FJUMT-01/02-30	30	123	1470
FJUMT-01/02-40	40	151	2360
FJUMT-01/02-50	50	192	3450

* FJZMT-01/02-08 están equipados con 2 cojinetes JSM-0810-16

** conforme al método de prueba igus® ► pág. 29.51

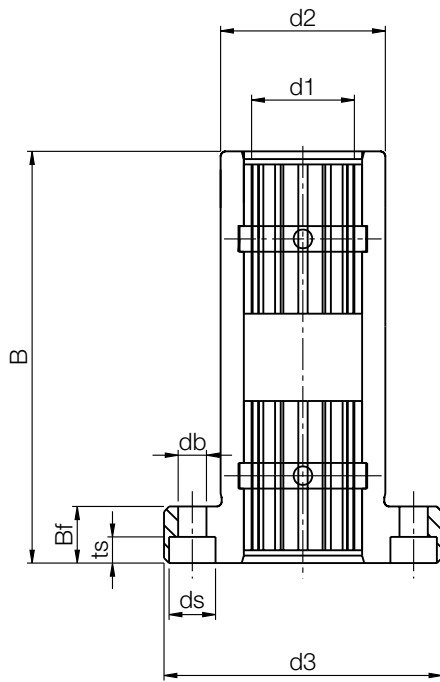

FJUMT-01-..

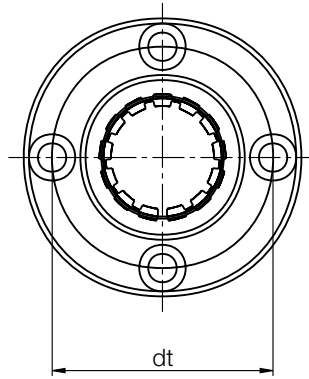

FJUMT-02-..

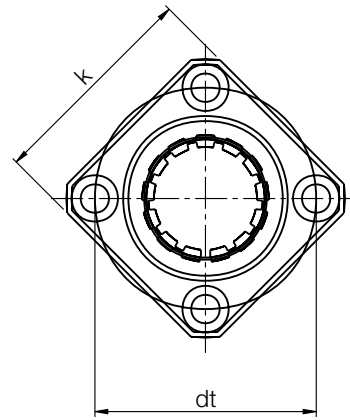

Otras dimensiones [mm]

Nº. de artículo	d1 [mm]	d2 [mm]	d3 [mm]	dt [mm]	k [mm]	B [mm]	Bf [mm]	ts [mm]	db [mm]	ds [mm]
FJZMT-01/02-08*	8	16	32	24	25	45	8	3.1	3.5	6.0
FJUMT-01/02-10	10	19	39	29	30	52	9	4.1	4.5	7.5
FJUMT-01/02-12	12	22	42	32	32	57	9	4.1	4.5	7.5
FJUMT-01/02-16	16	26	46	36	35	70	9	4.1	4.5	7.5
FJUMT-01/02-20	20	32	54	43	42	80	11	5.1	5.5	9.0
FJUMT-01/02-25	25	40	62	51	50	112	11	5.1	5.5	9.0
FJUMT-01/02-30	30	47	76	62	60	123	14	6.1	6.6	11.0
FJUMT-01/02-40	40	62	98	80	75	151	18	8.1	9.0	14.0
FJUMT-01/02-50	50	75	112	94	88	192	18	8.1	9.0	14.0

* Anchos nominales por debajo de 10 mm se entregan con cojinetes de deslizamiento cilíndricos introducidos a presión

Plazo de entrega: del almacén

DryLin® R
mm

Teléfono +34 - 936 473 950
Fax +34 - 936 473 951

